

# **Micro Cryo-Trap**

## **Model 971**

*for Liquid CO<sub>2</sub> Cooling*

Scientific Instrument Services, Inc.  
1027 Old York Road  
Ringoes, NJ 08551

Phone (908) 788-5550

**Part #951001M**  
*revised 10/ '98*

## Notice

The information in this document is subject to change without notice.

Scientific Instrument Services (S.I.S.) makes no warranty of any kind with regard to the material contained in this manual, including, but not limited to, the implied warranties of merchantability and fitness of the equipment and techniques therein described for a particular purpose.

S.I.S. shall not be liable for errors contained herein or for incidental or consequential damages in connection with the furnishing, operation, performance or use of the Micro Cryo-Trap described in this manual.

S.I.S. assumes no responsibility for the use or reliability of equipment that is not furnished by S.I.S.

The warranty of the Micro Cryo-Trap is for 90 days and includes all parts and labor. All service and repair including warranty repairs will be performed at the repair facilities of Scientific Instrument Services in Ringoes, NJ.

### Micro Cryo-Trap Installation Packages

Depending on the make and model of your Gas Chromatograph, one of the following Micro Cryo-Trap installation kits is required. No drilling or additional hardware is required. Kits for other makes and models of gas chromatographs will be added as required, so give us a call if you wish to use a GC not listed below.

#### Micro Cryo-Trap Installation Kits

Part #	Description
900110	Micro Cryo-Trap Installation Kit for Hewlett-Packard 5890A GC
900111	Micro Cryo-Trap Installation Kit for Hewlett-Packard 5890 Series I and II
900112	Micro Cryo-Trap Installation Kit for Hewlett-Packard 6890 GC
900113	Micro Cryo-Trap Installation Kit for Hewlett-Packard 5880 GC
900120	Micro Cryo-Trap Installation Kit for Varian 3400/3600/3700 GC with 1075/ 1040/ 1041 and 1077 Injectors
900121	Micro Cryo-Trap Installation Kit for Varian 3600 GC with 1078 Injector
900122	Micro Cryo-Trap Installation Kit for Varian 3800 GC
900130	Micro Cryo-Trap Installation Kit for Shimadzu GC-9A
900140	Micro Cryo-Trap Installation Kit for Finnigan GCQ GC/MS System

## Safety Information

- WARNING** Connecting the Micro Cryo-Trap to a power source which is not equipped with a protective earth ground contact creates a shock hazard for the operator and can damage the instrument.
- WARNING** Make sure that only fuses with the required current rating and of the specified type are used for replacement. The use of incorrect or make shift fuses or the short-circuiting of the fuse creates a shock hazard for the operator and can damage the instrument.
- WARNING** Any adjustment, maintenance or repair of the opened instrument while it is connected to a power source should be avoided if possible and, if required, should be carried out only by trained persons who are aware of the hazards involved.
- WARNING** Hazardous Temperatures - Keep hands and fingers from the Micro Cryo-Trap when it is operating. The Micro Cryo-Trap is subjected to both heating and cooling temperatures (-70° C to 400° C) which can cause severe burns.
- WARNING** The Micro Cryo-Trap Model 971 is designed for cooling using liquid CO<sub>2</sub> only. Do NOT use LN<sub>2</sub> or any other cooling gas.
- WARNING** Do not leave the Micro Cryo-Trap in either the heated or cooled position unattended overnight. The Micro Cryo-Trap will both heat and cool quickly to its final temperature. Therefore, in order to prolong the life of the Cryo-Trap, it should be turned off when not actively being utilized for analysis.
- WARNING** Due to the complexity of the internal wiring of the Micro Cryo-Trap, disassembly and repair should not be attempted by the user. **Disassembly will result in further damage to the Micro Cryo-Trap and will void all warranties.**
- WARNING** Avoid using excessive heat in the Micro Cryo-Trap to remove the trapped volatiles from the guard column. The Micro Cryo-Trap heating temperature should not exceed the maximum rated temperature of the guard column or decomposition of the liquid phase will occur. This will readily be apparent with the appearance of siloxane peaks ( M/e ions at 207, 281, 267, 355) in the chromatogram.

## Service

All service will be performed at the repair facilities of Scientific Instrument Services in Ringoes, NJ. If service is required, both the Cryo-Trap and its controller should be sent to the following address for repair.

**Scientific Instrument Services, Inc.**  
**1027 Old York Rd**  
**Ringoes, NJ 08551**  
**Attn: Repair Dept.**

# General Information

## Features:

- Only 1" long - uses minimum amount of cooling gas
- Dual Programmable Cryo-Cooling and Heating Cycles
- Trap Compounds in the GC Oven at the Head of the GC Column
- Trap is Positioned Directly under GC Injection Port
- Low Dead Volume Cryo-Trapping System
- Trap Volatiles down to -70°C using Liquid CO<sub>2</sub>
- Reduce CO<sub>2</sub> usage by >97% as Compared to Whole Oven Cooling
- Remote Input Connector for Cryo-Cooling to Heating Cycle Switching Via GC, Desorption System or Manual Control
- Rapid Heating up to 400°C at >400° per minute
- Remote Start Output Signal for Starting GC, MS or recorder
- Clamp mounts onto GC Injection Port

## Applications

The GC Cryo-Trap is designed for the trapping of volatiles and semi-volatiles injected into the GC injection port via all of the following techniques:

- Thermal Desorption Sample Trapping
- Purge and Trap Systems
- GC Head Space Analysis
- GC Syringe Injections
- GC Pyrolysis
- Multidimensional GC System Development

The new Micro Cryo-Trap was originally designed for use in conjunction with the S.I.S. Short Path Thermal Desorption System, however its application extends far beyond this as outlined above. Normally in order to cryo trap volatiles at the head of the GC column, the entire GC oven is cryo cooled using liquid CO<sub>2</sub> at temperatures not below -40°C. The new Micro Cryo-Trap extends this temperature range and provides for more efficient use of the CO<sub>2</sub>. The Micro Cryo-Trap mounts just under the GC injection port. This minimizes the dead volume between the GC septum and the Cryo-Trap which results in efficient trapping and optimum resolution of the trapped organic compounds when they are eluted from the Cryo-Trap and capillary column. With the Micro Cryo-Trap, volatiles can be trapped at temperatures down to -70°C at the head of the GC column, using less than 10% of the CO<sub>2</sub> required to cool the entire GC oven. After the organic compounds are cryo-trapped, the heater coil will rapidly heat the trap in excess of 400° per minute to its preset temperature to elute the organic compounds from the guard column for subsequent separation on the capillary GC column. This quick and efficient heating results in sharp, highly resolved GC peaks for all compounds. The Cryo-Trap mounts to the bottom of the GC injection port. No additional holes or drilling are required. The Cryo-Trap easily and quickly attaches to the mounting bracket using a clamp. The Cryo-Trap can be easily removed for accessibility of the GC injection port connection nut and for easy installation of columns and guard columns.

## Description of System

The Micro Cryo-Trap consists of a small heating/cooling chamber which is 3/4" in diameter and 1" long (**Figure # 1**). In the center of the chamber is a small stainless steel capillary through which the capillary column freely passes. Capillary columns up to megabore (0.53 mm I.D.) diameters can be used. Around the stainless steel capillary tube a heating coil is wound to provide for the rapid heating of the capillary tube. A thermocouple provides accurate measurement of both the cooling and heating temperatures and provides the signal for the accurate regulation of both the heating and cooling of the Micro Cryo-Trap by the dual range temperature controller. The liquid CO<sub>2</sub> for cooling is released into the top connector in the Micro Cryo-Trap, while the bottom connector serves as an outlet which can either be vented into the GC or a tube can be attached to vent the expired CO<sub>2</sub> external to the GC oven.

The control of the Micro Cryo-Trap is provided via an independent Micro Cryo-Trap Controller provided with the System or through the S.I.S.Short Path Thermal Desorption System Model TD4 as shown in **Fig. 2**. Both the Cryo Cooling and Heating temperatures are set via the digital temperature controller. Cryo-Cooling temperatures down to -70°C can be set via the controller using liquid CO<sub>2</sub> as the cooling gas. Heating temperatures, to remove the volatiles from the trap, of up to 400°C are achievable at a ramp rate of about 400° per minute. This provides more than sufficient heating to release both volatiles and semi-volatiles from the trap efficiently with sharp and narrow peak shapes. Use care not to exceed the maximum rated temperature limit of the guard column or column bleed peaks will appear in your chromatogram.

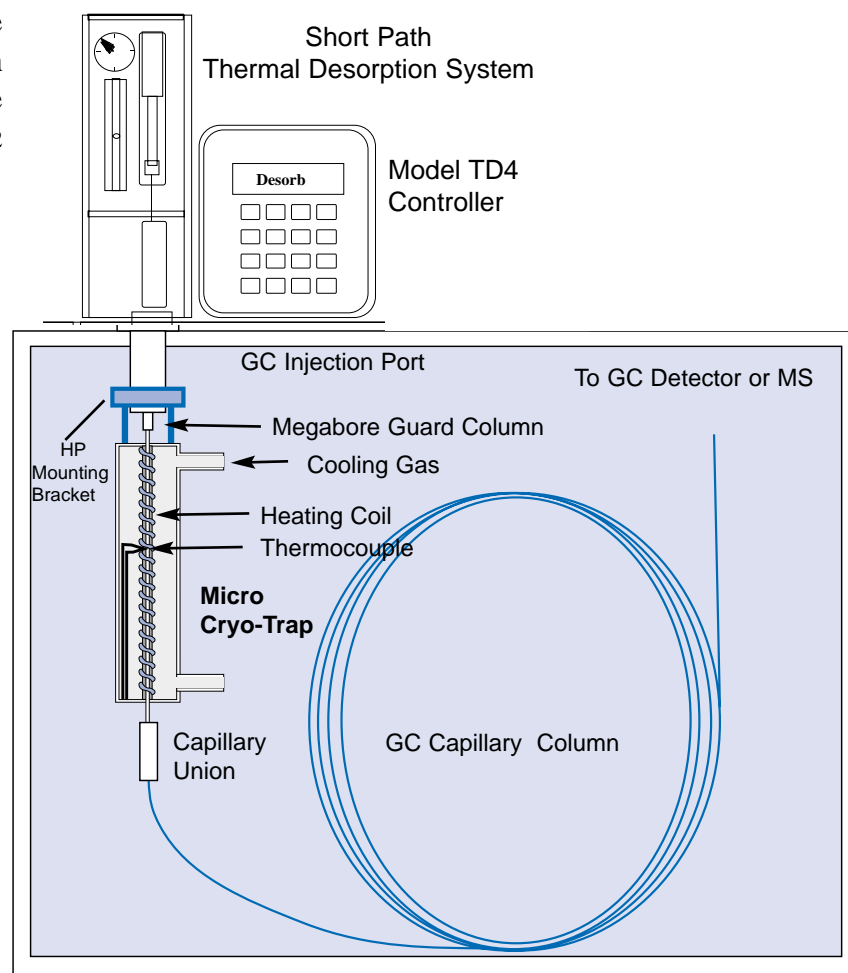
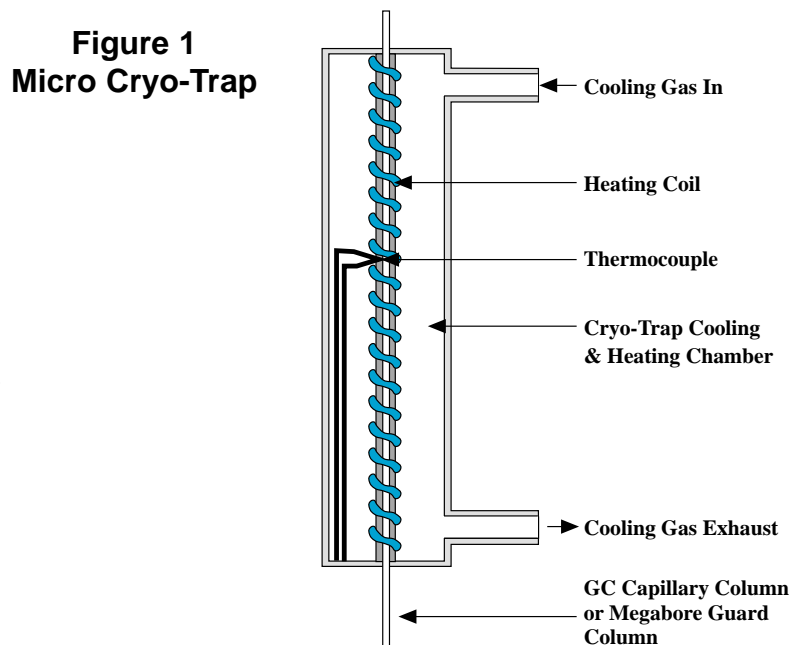

The Cryo-Trap System comes complete with Micro Cryo-Trap, liquid CO<sub>2</sub> valve, and Dual Temperature Controller. An installation kit for your make and model of GC must be ordered separately. Power requirements are 110 VAC, 3 amp max. An external supply of liquid CO<sub>2</sub> is required for the cooling operation.

The Micro Cryo-Trap was also designed to be used with the S.I.S. Short Path Thermal Desorption System TD4 (**Fig. 3**). Micro Cryo-Trap Models are available which can be installed in the TD4 controller which permits the Short Path Thermal Desorption System to be used for the automatic control of the Micro Cryo-Trap. The Thermal Desorption System electronics will control both the cooling and heating temperatures. When the desorption process is complete, the Thermal Desorption system will activate the Micro Cryo-Trap to switch from the cooling cycle to the heating cycle and begin the GC oven temperature program. The new Model TD4 Short Path Thermal Desorption has all the Micro Cryo-Trap control circuitry built into the electronics including cooling and a programmable heating rate from 1 to 40 degrees per minute.

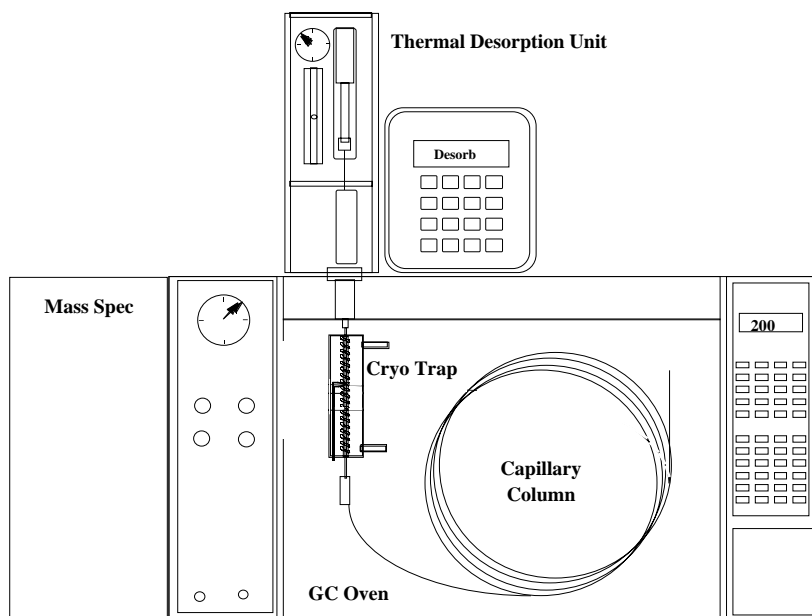

**Figure 3 Complete GC/MS/TD/Cryo-Trap System**

Other applications of the Micro Cryo-Trap include the trapping of volatiles from purge and trap systems, trapping of volatiles from GC head space systems, standard GC injection trapping and pyrolysis system trapping. This technique will permit the injection of larger samples over a longer period of time and will improve peak shapes, especially of the early fast eluting compounds. The Micro Cryo-Trap could also be developed into a system for Multidimensional GC analysis, although to date this has not been done at S.I.S.

The chart at the right (**Fig. 4**) shows the usefulness of the Micro Cryo-Trap for the trapping of straight chain hydrocarbons C-5 through C-9. For this analysis a Guard column was used inside the Cryo-Trap which consisted of a DB5 column, 0.53 mm I.D. x 70 mm long x 5.0 u film thickness. At the exit of the Micro

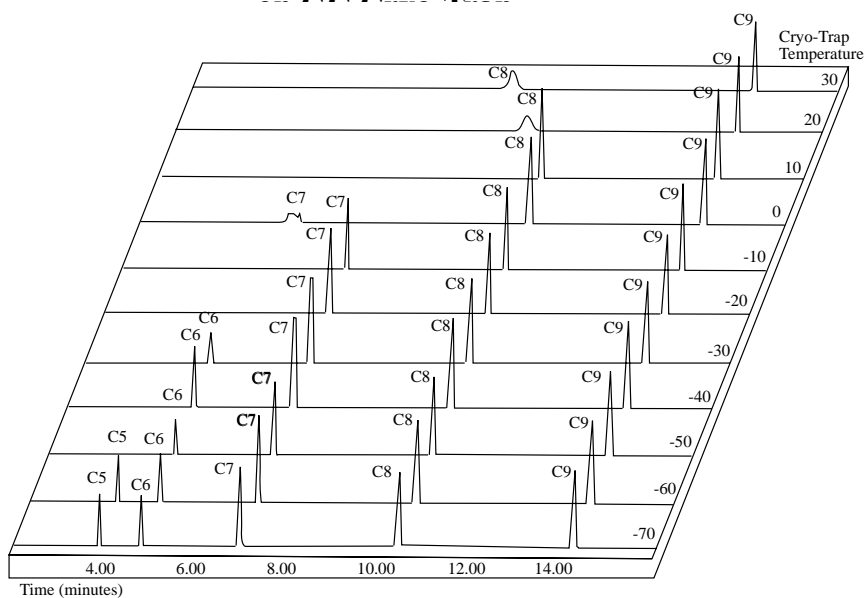

**Figure 4 Trapping Efficiency of Hydrocarbons on Micro Cryo-Trap as a Function of Trapping Temperature**

Cryo-Trap a capillary union was used to attach the guard column to a DB-5-MS capillary column, 0.25 mm x 60 meter x 0.25 u film thickness. By decreasing the temperature of the Micro Cryo-Trap from room temperature down to  $-70^{\circ}\text{C}$ , the efficiency of trapping the volatiles was increased. Normal use of a cryo-cooling GC oven can just barely trap Hexane (melting point  $-95$ ), however, by using the Micro Cryo-Trap this can be extended down to pentane (Melting point  $-130$ ). We have been able to accurately quantify Acetone, ethyl acetate, methylene chloride, and chloroform in pharmaceuticals using the Cryo-Trap in conjunction with the direct thermal extraction technique and the S.I.S. Short Path Thermal Desorption System. (Data available on the internet at <http://www.sisweb.com>).

### Guard Columns

A wide variety of guard columns can be used with the Micro Cryo-Trap depending on the users preference. The purpose of the guard column is to trap the volatiles and semi-volatiles on the surface or on the liquid phase of this section of column inside the Cryo-Trap and then to rapidly release these organics when the guard column is heated. Normally the guard column should not extend more than 20 mm beyond the bottom of the Cryo-Trap. A low dead volume connector is used to join the guard column to the GC capillary column (**Fig. 2**). A comparison of several guard columns is shown in **Figure 5**. This study compares a deactivated fused silica guard column, which traps volatiles based strictly on the freezing point of the volatiles, to various liquid phase coated guard columns, which increase the range of low boilers which are trapped due to the interaction between the volatiles and the liquid phase coating. Thick film liquid phase coatings provide for the optimum retention of the low boilers, however they have a limited temperature range and may not release the higher boiling compounds. For the analysis of volatiles, the thick film guard columns are normally used. For the analysis of semi-volatiles (such as the PNA's) uncoated deactivated fused silica columns are normally used. Megabore guard columns are recommended due to their larger surface area and ability to handle larger samples and samples with higher water content. In contrast microbore guard columns would provide for slightly higher resolution but are more susceptible to the formation of ice plugs if the samples contain any appreciable levels of water.

For optimum peak resolution, we recommend using a deactivated fused silica guard column. This guard column provides a good surface for cryotrapping compounds with melting points down to the cryo trap temperature. By using a megabore guard column, the occurrence of water plugs can be minimized in the cryo trap section of this guard column. The larger internal diameter and surface permits the trapping of samples with higher moisture content than microbore capillary guard columns.

By using guard columns with liquid phases, compounds with melting points below the cryotrap temperature can be trapped. The thicker the liquid phase, the better the trapping efficiency. For example by using a 0.53 mm I.D. DB-5 Megabore column with a 5.0 u film thickness, compounds with melting points down to  $-130$  (i.e. Pentane) can be trapped at a cryo trap temperature of  $-70^{\circ}\text{C}$ . When using these liquid phase coated guard columns, some loss in resolution, especially at the lower end of the chromatogram may be observed, but much lower volatiles will be trapped than would otherwise be possible. When using these thick

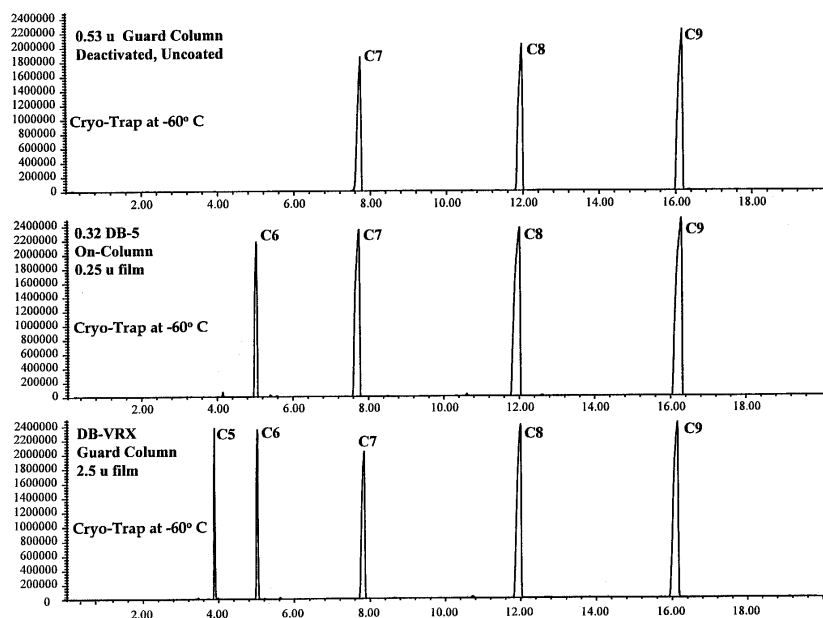

**Figure 5 Effect of Guard Column on the Trapping Efficiency of Hydrocarbons at  $-60^{\circ}\text{C}$**

film megabore guard columns, make a union to your capillary column as close to the Micro Cryo-Trap module as possible. If this is not done, additional loss in resolution will occur since the guard column will begin to act as the analysis column during temperature programming of the GC oven.

## **Site Preparation**

### **Connecting Liquid CO<sub>2</sub>**

The liquid CO<sub>2</sub> tank must be equipped with an internal eductor (dip) tube to ensure the delivery of liquid CO<sub>2</sub> rather than gas to the Micro Cryo-Trap. DO NOT use a gas regulator on the CO<sub>2</sub> tank or anywhere in the liquid transfer line to the controller. The liquid is taken from the tank at full pressure. No insulation of the CO<sub>2</sub> line is required. Use 1/8" stainless steel tubing to transfer the liquid CO<sub>2</sub> from the tank to the 1/8" fitting on the CO<sub>2</sub> valve.

## **Installation of the Micro Cryo-Trap on the H.P. 5890 Gas Chromatograph**

The Micro Cryo-trap consists of three components; the Electronics Console, the Cryo-Trap Module and the remote CO<sub>2</sub> valve. The Electronics Console is designed to sit on top of or in close proximity to the Gas Chromatograph (**Fig. 2 and 3**). The Cryotrap Module is designed to be mounted inside the GC oven just under the front injection port. The Micro Cryo-Trap is then clamped to the GC injection port. The only modification to the GC that is required is the removal of the GC injection port cover as explained below. The CO<sub>2</sub> valve should be mounted as close as possible to the entrance of the CO<sub>2</sub> line into the GC oven wall. No additional mounting screws or drilling of holes is required.



# Installation of the Micro Cryo-Trap

## Installation of the Cryo-Trap Module on the HP 5890 GC

### Step 1

Begin by opening the GC oven door. Initial installation can best be accomplished with the GC column removed. However, installation can be accomplished with the column installed provided that extreme care is taken by the installer to avoid breaking the GC column. First, loosen the 2 screws (**Figure 6**) and remove the protective covering from beneath the injection port (**Figure 7**). Install the flat replacement protective cover supplied with the GC Cryo-Trap using the same two screws. (**Figure 8**)



## Step 2

Slide the 1/16"OD x 1.0 meter length of ss tubing (part #951300) through one of the exit ports in the GC oven. A convenient GC oven exit to use is the port for a second GC injection port (**Figure 9**). This second GC injection port exit is preferred due to its close proximity to the Cryo-Trap in the GC oven. Carefully move the insulation in this port to one side, or if preferred remove this plug of insulation for the easy passage of the CO<sub>2</sub> tube. Other exit ports such as spare detector ports could also be used. It will be necessary to bend this tubing to point toward the GC injection port. (**Figure 9**)

## Step 3

Feed the Electrical lead up behind the Cryo-Trap module (**Figure 10**) through the same hole that the liquid CO<sub>2</sub> ss tubing was placed.

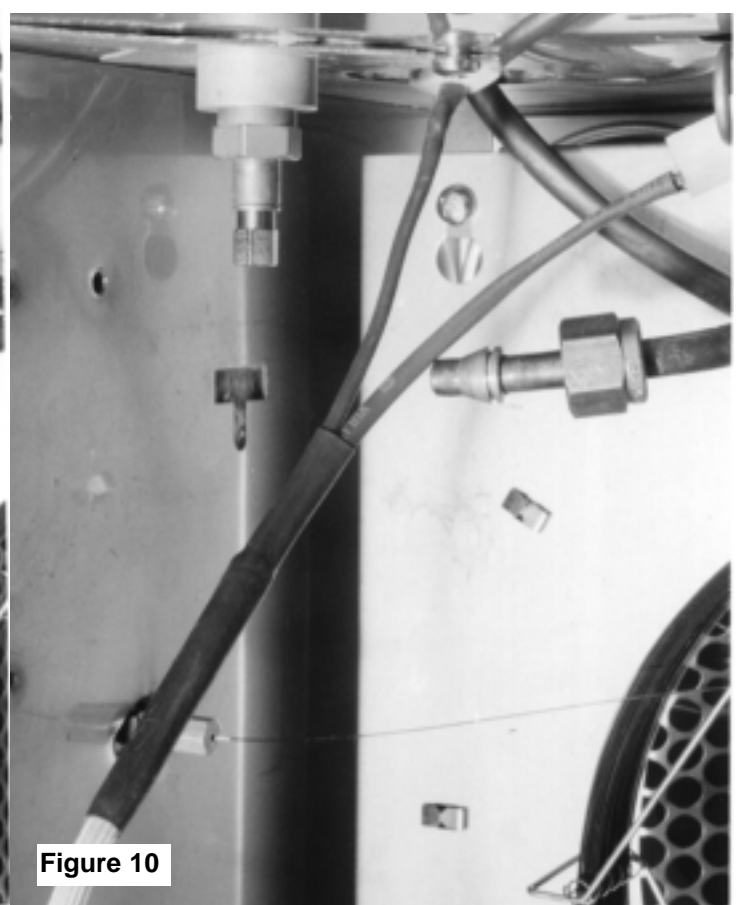
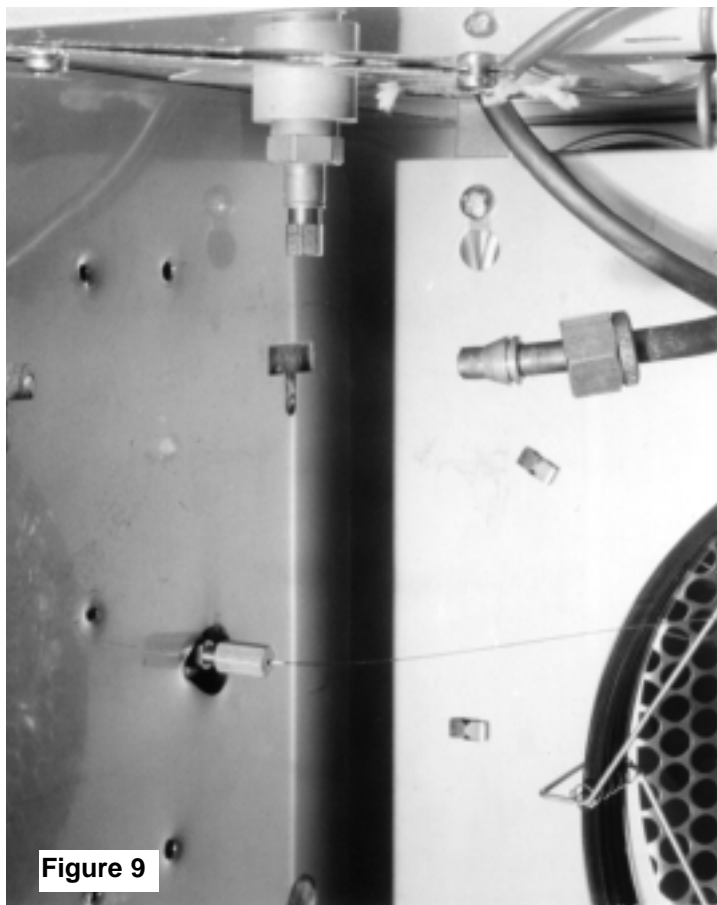

#### Step 4

The Cryo-Trap is designed to clamp to the stem of the GC Injection Port fitting that attaches to the GC Injection Port using the knurled screw clamp. See **Figures 11 & 12**. Loosen the knurled nut clamp, slide the Micro Cryo-Trap over the injection port fitting ( **Fig. 11**) and then clamp onto the stem of the GC Injection Port ( **Fig. 12**).

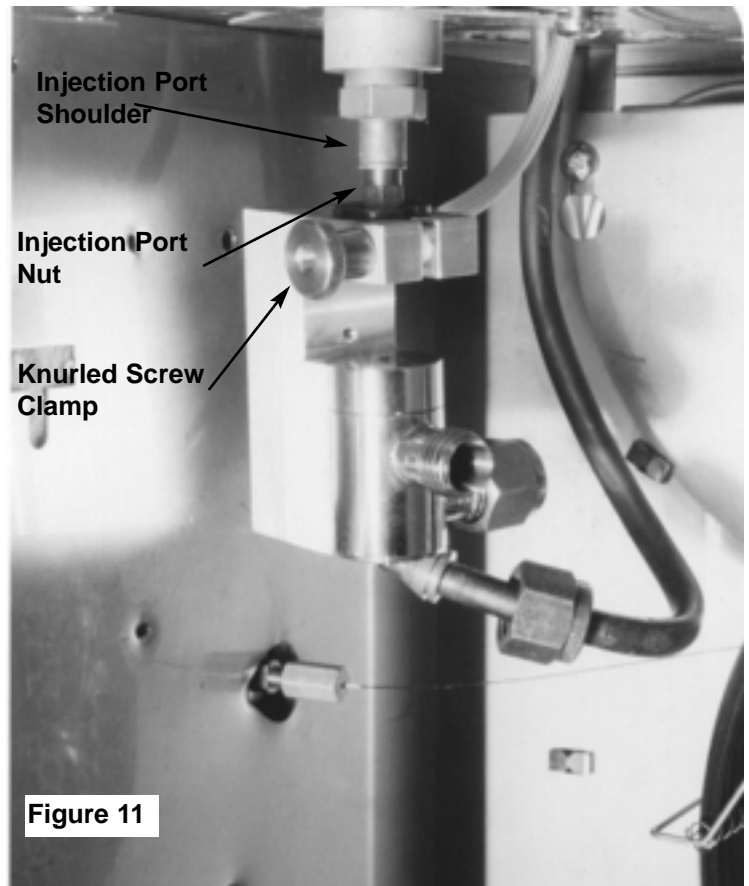

Figure 11

#### Step 5

Bend the ss tubing and attach 1/16" Swagelok fitting to mate the Liquid CO<sub>2</sub> line to the Micro Cryo-Trap. Tighten the 1/16" Swagelok fittings securely.

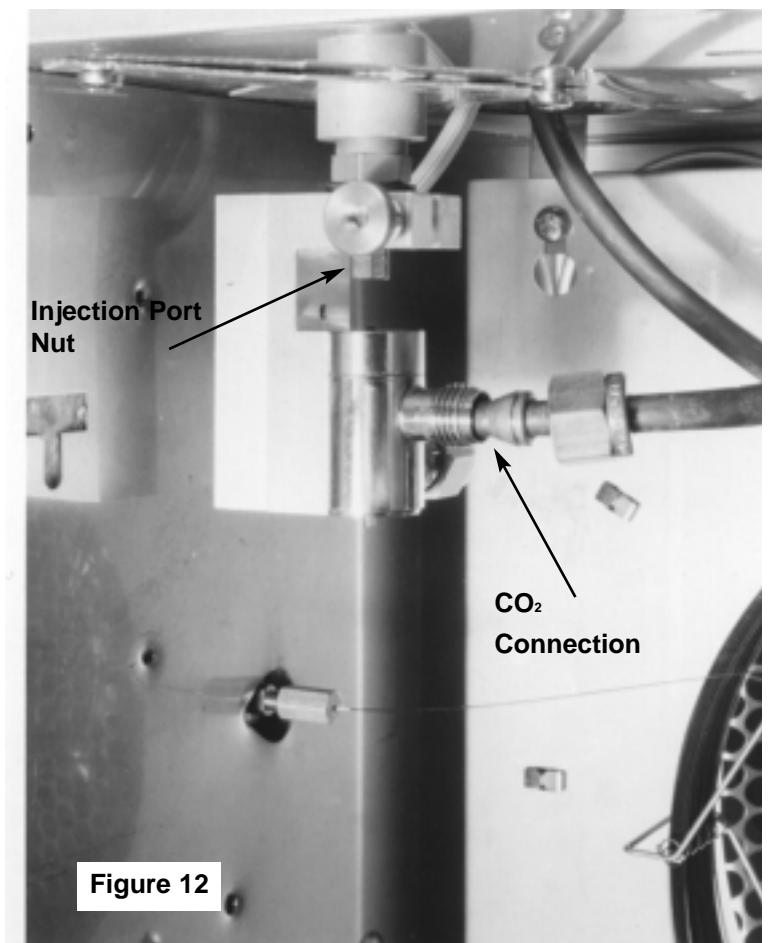
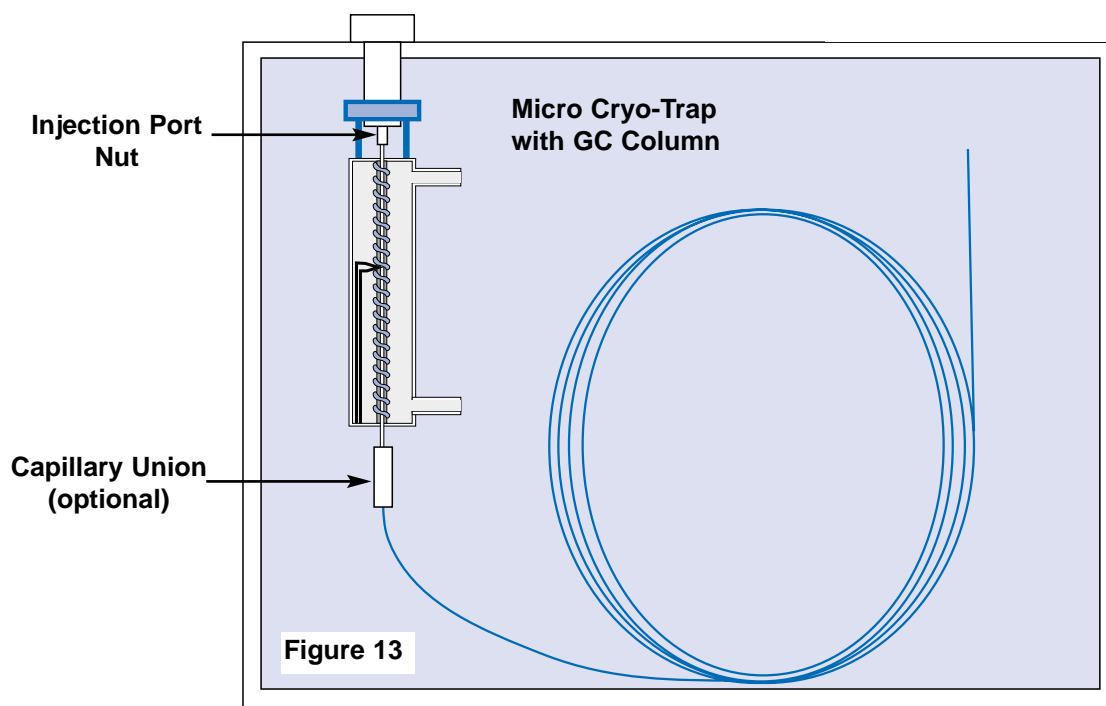

Figure 12

Model 961 Installation

## Step 6

Install the GC capillary column in the GC oven (**Figure 13**). Depending on whether the capillary column itself or a guard column is to be used for trapping in the cryo-trap, insert this capillary column inside the Micro Cryo-Trap module from the bottom. If necessary loosen the Micro Cryo-Trap clamp and slide the Micro Cryo-Trap module downwards to temporarily remove the Micro Cryo-Trap to allow more room for attaching the capillary column to the GC Injection Port Fitting.



### Step 7

After the capillary column (or guard column) has been inserted through the Micro Cryo-Trap module, attach the GC injection port fitting and appropriate column ferrule (**Figure 14**). The Micro Cryo-Trap module can be lowered to better facilitate the attachment of these fittings. It is also advisable to cut the end of the capillary off after the ferrule has been attached to avoid any possibility of ferrule contaminants from entering the column. Then slide the column up into the GC injection port the required distance and tighten the fitting and ferrule to hold the column in place.

### Step 8

When the capillary column has been attached, tighten the Micro Cryo-Trap clamp to provide a gap of between 2 to 10 mm between the GC injection port capillary nut and the top of the Micro Cryo-trap. This will minimize the dead volume between the injection port and the Micro Cryo-Trap module and still maintain a thermal barrier between the injection port and the Micro Cryo-Trap module.

### Step 9

If a guard column was used, cut the end of the guard column to within 25 mm from the bottom end of the Cryo-Trap module and join this end to the capillary column using an appropriate fitting. (**Figure 13**) When joining most microbore capillary columns to megabore guard columns, the capillary column will slide inside the guard column for 10 to 20 mm to minimize any possibility of active metal surfaces being exposed to the samples being analyzed.

**Note:** We prefer to use the SGE low dead volume unions for this connection.

### Step 10

Tighten all fittings and attach the other end of the column to the detector or Mass Spectrometer.

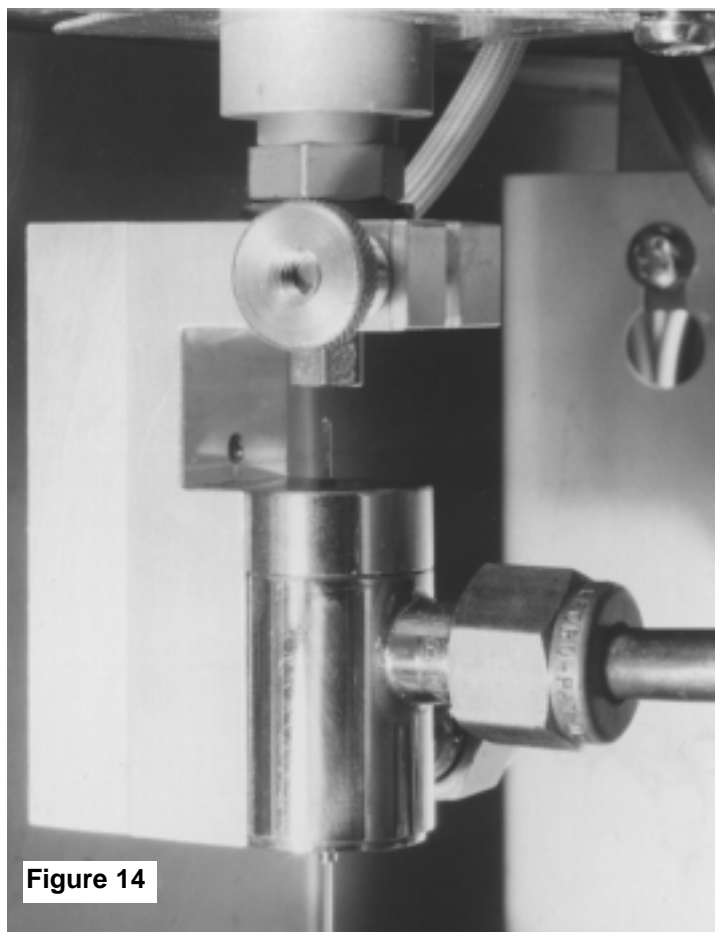

## Electronic Control Connections

### Step 11

Attach the lead from the Micro Cryo-Trap module to the connector labeled “Cryo-Trap” on the back of the Micro Cryo-Trap Electronics console (**Figure 15**).

### Step 12

Connect the plug at the end of the CO<sub>2</sub> valve control lead to the CO<sub>2</sub> valve connector socket on the back of the Micro Cryo-Trap controller. (See **Figure 15**)

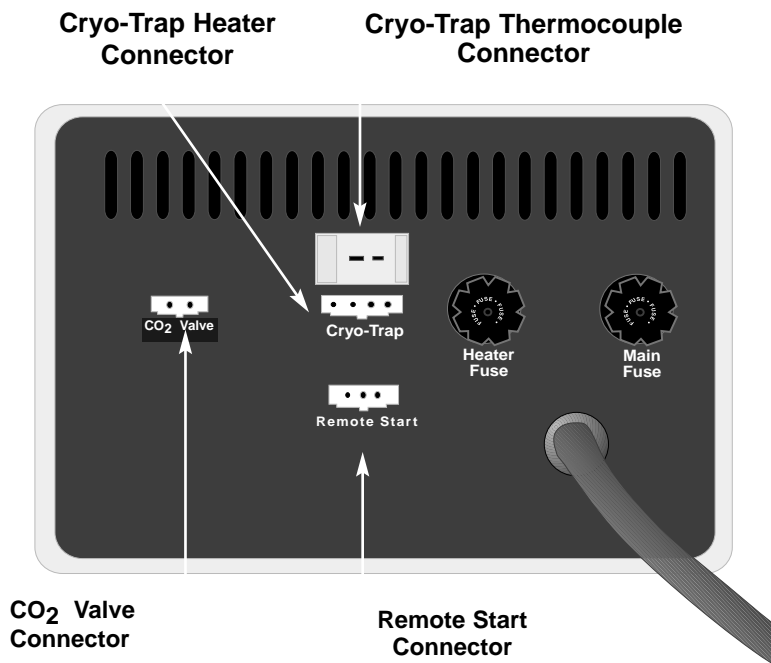

Figure 15

### Step 13

Connect 1/8” tubing from your source of liquid CO<sub>2</sub> to the 1/8” fitting on the inlet side of the electronic CO<sub>2</sub> valve (see **Figure 16**). The 1/16” ss tubing (#951300) which was installed on the Micro Cryo-Trap earlier is for connection to the outlet side of the CO<sub>2</sub> valve. Connect the line leading from the Micro Cryo-Trap to the outlet end of the valve. The inlet and outlet fittings are clearly marked on the valve.

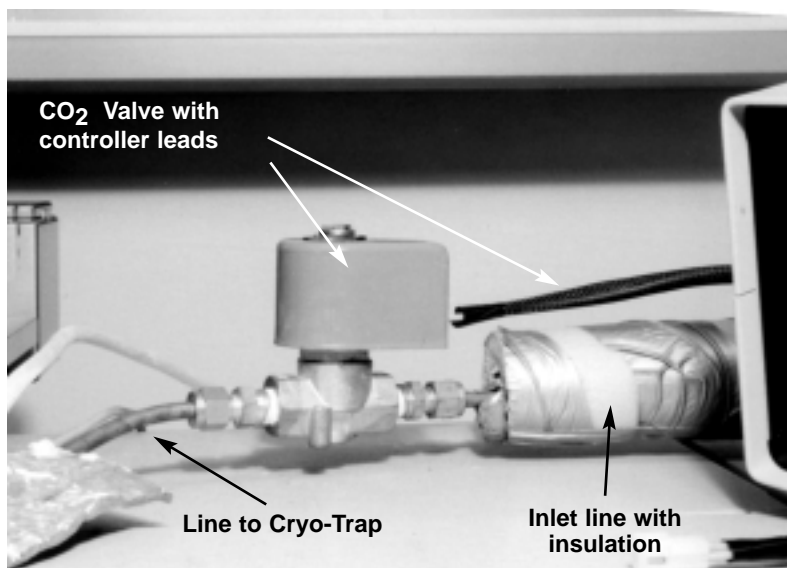

Figure 16

# Operation of the Micro Cryo-Trap

## Description of the Electronics Console

The electronics Console front panel consists of a main power switch, a rotary select switch and the digital dual temperature controller module.

### Main Power Switch

The Power switch controls the power to the entire Micro Cryo-Trap Electronics Console as well as the Cryo-Trap module. When this switch is turned OFF, neither heating power or cooling liquid is input to the Cryo-Trap module. When the Micro Cryo-Trap is not being used, it should be left in the OFF position.

### Rotary Select Switch

The rotary select switch permits the selection of the mode of operation. In the OFF position no heating power or CO<sub>2</sub> liquid cooling is being supplied to the Cryo-Trap module. This is the normal standby position when the Micro Cryo-Trap is not being actively utilized to trap or analyze a sample. In the COOL position, liquid CO<sub>2</sub> is supplied to the Cryo-Trap module to cool this module down to its preset cooling point which has been pre selected and set via channel 2 on the temperature controller. The system will regulate and hold near this preset cooling temperature in the COOL position. In the HEAT position, current is supplied to the Cryo-Trap module to regulate its temperature to the value which has been pre selected via channel 1 on the temperature controller. Both the HEAT and COOL positions on this rotary switch are designed for the manual operation of the Micro Cryo-Trap. They can also be utilized to override or supplement the operation of the automatic mode of operation.

The AUTO position on the rotary switch is designed for automatic operation and control of the heating and cooling cycles of the Micro Cryo-Trap via an external input to the Electronics Console from an external device. This controlling signal is provided via the remote input connector on the back of the Electronics Console. The input consists of two wires. When these wires are shorted, via a closure of a switch between these two inputs, the Micro Cryo-Trap channel 2 is activated, which causes the system to operate in the COOL mode. When these wires are open, the Micro Cryo-Trap operates in the HEAT mode and is controlled and regulated via channel 1 on the temperature controller.

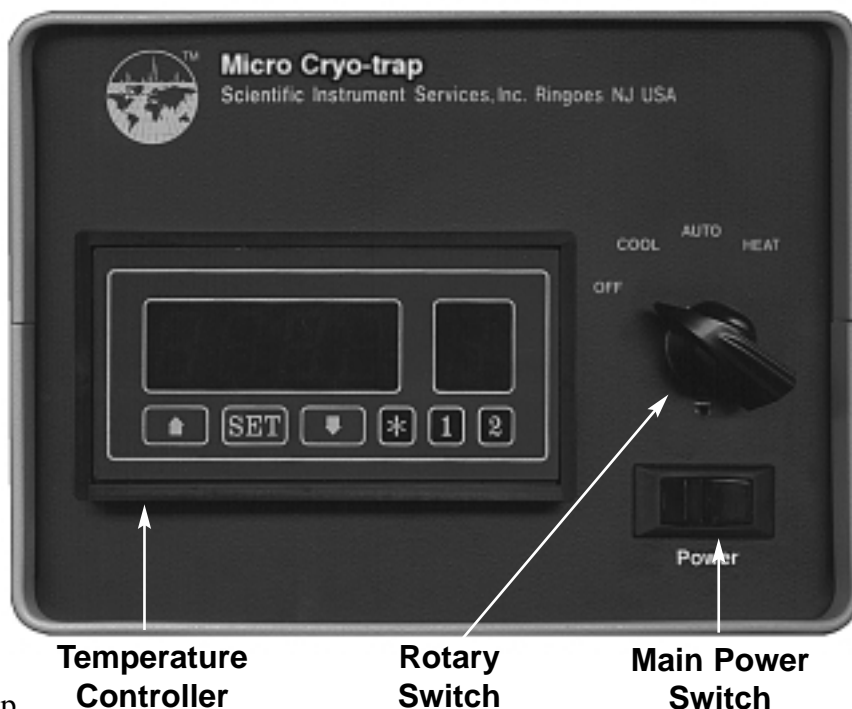

Figure 16

## **Digital Dual Temperature Controller**

The Digital Dual Temperature Controller permits the user to input both the cryo cooling set point temperature for trapping volatiles in the Cryo-Trap module and the Heating set point temperature to elute the volatiles from the Cryo-Trap module. A single thermocouple in the Cryo-Trap module provides the temperature signal feedback to the temperature controller to control and regulate both of these temperatures. The heating cycle temperatures are controlled via Channel 1 on the temperature controller and the cryo cooling cycles are controlled via Channel 2 on the temperature controller. The red LED display panel shows the actual temperature in degrees Centigrade when the letter “C” is displayed in the last right digit of the LED display.

In order to set the heating and cooling temperatures to the users requirements, the SET button on the Temperature Controller should be pushed once. When this is done, the display will indicate a flashing “S” in the last right digit of the LED display. The left digits will display the current setting for the temperature and either “1” or “2” will be lit at the bottom of the display. A “1” indicates that the Channel 1 temperature or the heating preset temperature is being displayed and can be changed by the user at this time. To change the temperature use the two arrow keys to either raise or lower the temperature to the required value. When finished, push the SET button again. The new pre selected heating temperature has been stored and the system is ready for the next input. A “2” indicates that Channel 2 temperature or the Cooling temperature is being displayed and can be changed by the user. Use the two arrow keys to select the required COOL temperature. When finished, push the SET button once again. Both the heating and cooling values selected are now stored in the controller and will remain in the controller even if the main power switch is turned OFF. After the new set points have been input to the temperature controller, the display should once again read the current Micro Cryo-Trap temperature in degrees C and the letter “C” should appear in the right digit of the LED display.

NOTE: After you push the SET button to input data, the temperature will wait 10 seconds for you to input or change the temperature settings. If no input is received within 10 seconds, the controller will exit the temperature edit mode and automatically return to the standard operating mode.

NOTE: Channel 1 (heating mode) only operates the heater in the Micro Cryo-Trap. This circuit cannot cool down below room temperature. Likewise Channel 2 (cooling mode) only operates a valve which regulates the cooling of the Micro Cryo-Trap. This circuit cannot heat the Micro Cryo-Trap above room temperature.

## **Micro Cryo-Trap Standard Operating Methodology**

### **Modes of Operation**

The Micro Cryotrap has two basic modes of operation, manual and automatic. The automatic mode is designed to operate with the S.I.S. Short Path Thermal Desorption System the GC as described later in this manual, or other systems configured to operate using the remote cable to switch between heating and cooling. In the manual mode of operation, the system can be switched from heating to cooling, manually via the rotary switch on the front panel of the Electronic console for the Micro Cryo-Trap system.



## Manual Mode

(1) Select the desired Cryo-Trap temperatures for both the Cooling and Heating cycles as described above. Normally a heating temperature between 100 and 250°C is used for the release of the trapped volatiles from the Cryo-Trap. Use care not to exceed the maximum temperature of the guard column. A Cryo-Cooling temperature between +10° and -70°C is normally used for the trapping of the volatile organics in the Micro Cryo-Trap. The temperature you select depends on the compounds being analyzed.

(2) After the GC column is cooled down to its initial starting position as set by the GC, turn the rotary switch on the Micro Cryo-Trap to the COOL position. This will cool the Cryo-Trap module down to the required cooling temperature. When the cooling temperature is reached, the GC samples can be injected into the GC injection port for subsequent trapping in the Micro Cryo-Trap.

(3) When the sampling is complete, turn the rotary switch on the Micro Cryo-Trap to the HEAT position and begin the GC column temperature program. The Micro Cryo-Trap will rapidly heat up to the pre selected heating temperature to elute the volatiles from the guard column inside the Micro Cryo-Trap module and elute these organics through the GC column.

(4) When the GC run is complete, turn the rotary switch to the OFF position until ready for the next sample to be analyzed.

## Automatic Mode of Operation

(1) Select the desired Cryo-Trap temperatures for both the Cooling and Heating cycles as described above. Normally a heating temperature between 100 and 250°C is used for the release of the trapped volatiles from the Micro Cryo-Trap. Use care not to exceed the maximum temperature of the guard column. A Cryo-Cooling temperature between +10° and -70° C is normally used for the trapping of the volatile organics in the Micro Cryo-Trap. The temperature you select depends on the compounds being analyzed.

(2) After the GC column is cooled down to its initial starting position, turn the rotary switch on the Micro Cryo-Trap to the AUTO position. The temperature cycle of the Cryo-Trap is now controlled via the input from the remote cable as described previously.

(3) The remote device should be set up to cool the Cryo-Trap module down to the required cooling temperature (input connections are closed or shorted). When the cooling temperature is reached, the GC samples can be injected into the GC injection port for subsequent trapping in the Micro Cryo-Trap.

(4) When the sampling is complete, the remote device should switch to the heating cycle and begin the GC column temperature program (input connection are open). The Micro Cryo-Trap will rapidly heat up to the pre selected heating temperature to elute the volatiles from the guard column inside the Cryo-Trap module and elute these organics through the GC column.

(5) When the GC run is complete, the rotary switch can be left in the AUTO position until ready for the next sample to be analyzed.

## **Operation of the Micro Cryo-Trap with the S.I.S. Short Path Thermal Desorption System**

- (1) Select the desired Cryo-Trap temperatures for both the Cooling and Heating cycles on the Model TD4 controller. Normally a heating temperature between 100 and 250° C is used for the release of the trapped volatiles from the Micro Cryo-Trap. Use care not to exceed the maximum temperature of the guard column. A Cryo-Cooling temperature between +10° and -70° C is normally used for the trapping of the volatile organics in the Micro Cryo-Trap. The temperature you select depends on the compounds being analyzed.
- (2) The Cooling cycle for the Micro Cryo-Trap can be started by pushing the “Cryo Mode” button on the TD4 controller. The display should read “Cooling”.
- (3) When the cooling temperature is reached, the “Auto Start” button on the Thermal Desorption System can be pushed to initiate the Desorption Process. The GC samples are injected into the GC injection port for subsequent trapping in the Micro Cryo-Trap.
- (4) When the sampling is complete, the Thermal Desorption System will automatically switch the Micro Cryo-Trap to the heating cycle and begin the GC column temperature program (input connection are open). The Micro Cryo-Trap will rapidly heat up to the pre selected heating temperature to elute the volatiles from the guard column inside the Micro Cryo-Trap module and elute these organics through the GC column.

## **Trouble Shooting The Micro Cryo-Trap**

### ***(1) Main power switch will not light.***

Check the main fuses on the electronics console and replace if burned out. Replace with 1 Amp slow blow fuses, (S.I.S. part # 326-001).

### ***(2) Cryo-Trap Heater will not heat***

Check the heater fuse on the back of the Electronics Console and replace if necessary with a new 1 amp slo-blow fuse (S.I.S. part # 326-001).

Check that the heater/thermocouple cable is fully plugged into the plug in the electronics console.

Check that the heating temperature (Channel 1) has been set to a value above room temperature.

Check the resistance through the Cryo-Trap module heater with an ohm meter. Resistance through the heater should be approximately 22 ohms. If not close to this value the Cryo-Trap module should be returned to S.I.S. for servicing.

### ***(3) Cryo-Trap will not cool***

Check that the CO<sub>2</sub> tank is not empty.

Check that cooling temperature (Channel 2) on the temperature controller has been set to a value lower than room temperature.

Listen for the clicking sound of the solenoid valve for the cooling gas. Switch the rotary switch between OFF and COOL. If no sound is heard the CO<sub>2</sub> valve may be defective and should be sent in to S.I.S. for service.

**(4) Temperature on the LED display reads a value in excess of 400 degrees.**

Check the heater/thermocouple plug to assure that it is fully plugged into the socket on the back of the electronics controller.

Unplug the heater/thermocouple plug and measure the resistance through the thermocouple in the Cryo-Trap. The resistance should measure approximately 10 ohms. If the reading is infinite, the thermocouple is open and the Micro Cryo-Trap should be sent to S.I.S. for service.

**Specifications**

Electrical Power; 110 volt, 60 Hz, 1.0 amp max

Cryo-Trap module

Heater resistance: 22 ohm

Thermocouple resistance; 10 ohm  
at room temperature

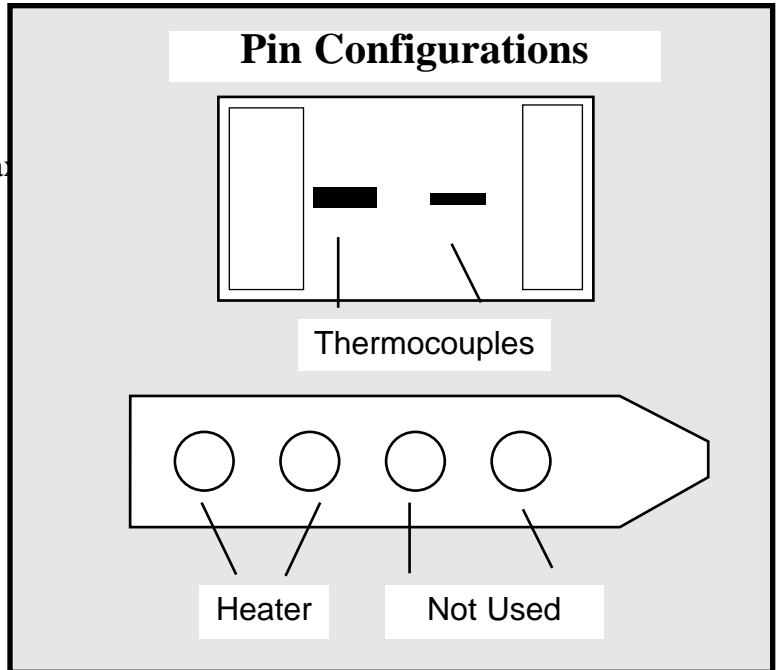

# **Installation of the Micro Cryo-Trap on Varian and Other Manufacturers Gas Chromatographs**

## **Introduction**

The Micro Cryo-Trap can easily be installed in the Varian 3400 GC as well as other GC's such as the Shimadzu GC. The mounting bracket is essentially the same except that a GC injection port fitting must be utilized with the mounting bracket. This is described below. Referring to the pictures in the HP Installation section of this manual may be helpful. The theory and operation and control of the Micro Cryo-Trap are identical to that described previously.

The Micro Cryo-Trap consists of two components, the Electronics Console and the Cryo-Trap Module. The Electronics Console is designed to sit on top of or in close proximity to the Gas Chromatograph. The Micro Cryo-Trap is designed to be mounted inside the GC oven just under the GC injection port. A mounting bracket designed for the Varian and other manufacturers is included with each system. This mounting bracket is designed to clamp to the 1/4" stem of the capillary fitting which attaches to the GC injection port. Therefore it is self aligning and no additional mounting screws or the drilling of holes is required.

## **Installation of the Micro Cryo-Trap Module**

### **Step 1**

Begin by opening the door on the gas chromatograph and disconnecting the capillary column from the GC injection port. It is preferred that the entire capillary column be removed for the installation of the GC Cryo-Trap in order to prevent damage to the delicate capillary column.

### **Step 2**

The Cryo-Trap mounting bracket is designed to clamp to the 1/4" stem of the GC injection port fitting (or GC insert) that attaches to the GC injection port. In some manufacturers of gas chromatographs there may be sufficient length of this 1/4" unthreaded stem to permit the clamp of the Cryo-Trap mounting bracket to be attached. However in most instances it will be necessary to remove the capillary column nut and its associated injection port fitting from the GC injection port and install the nut and fitting supplied with the Micro Cryo-Trap Installation Kit. For the Varian 1078 Injector it is necessary to replace the standard vespel sleeve included in the installation kit ( Part #900121). The Micro Cryo-trap will then clamp to the newly installed sleeve fitting that came in the Micro Cryo-trap Installation Kit.

### Step 3

The Micro Cryo-Trap horizontal positions are fixed, since the trap is aligned by the mounting bracket directly under the GC injection port. To adjust the height of the Micro Cryo-Trap, loosen the two knurled nuts on the Cryo-Trap mounting bracket. The Micro Cryo-Trap can then be positioned up and down slightly. This will permit the installation and attachment of the capillary columns.



## Step 4

The Micro Cryo-Trap leads, cooling gas lines, GC column and the installation of the electronics console are identical to the installation in the Hewlett Packard Gas chromatographs.

### Micro Cryo-Trap Installation

